

XIMEA

Gpixel: PulSar

Jan-H. Budde



- Electromagnetic spectrum and their application
- Expanding the spectral sensitivity
- Spectral sensitivity of GSENSE400BSI-TVISB (not PulSAR)
- Expanding the spectral sensitivity: Removing AR-coating (GSENSE400SBSI)
- Expanding the spectral sensitivity: Reduction of dead layer (GSENSE400BSI-PS)/ GSENSE400BSI-BPM-NPN-AR)X
- Comparison device specification
- Summary of PulSar technology
- Appendix I: Technical drawing XIMEA GSENSE400BSI-PS integration
- Appendix II: Comparison of spectral sensitivity improvements of GSENSE400BSI

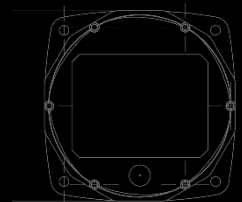

Gpixel announce new PulSar technology

Electromagnetic spectrum

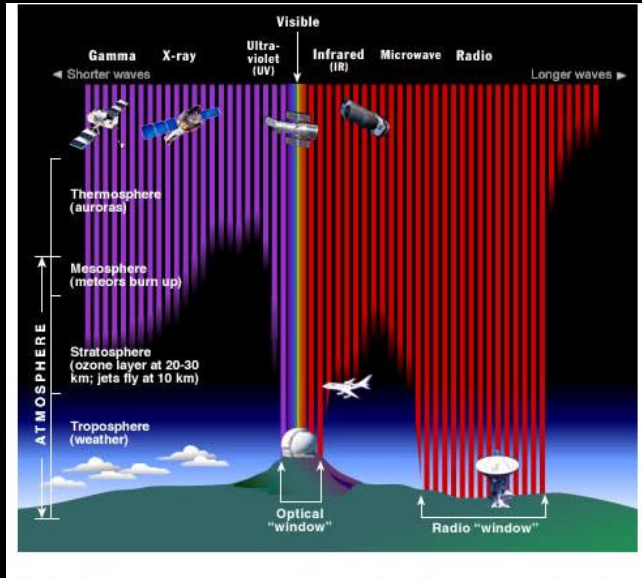

The Earth's **atmosphere** stops most types of electromagnetic radiation from space from reaching Earth's surface. This illustration shows how far into the atmosphere different parts of the EM spectrum can go before being absorbed. Only portions of radio and visible light reach the surface. (Credit: STScI/JHU/NASA)

[Electromagnetic Spectrum - Introduction \(nasa.gov\)](#)

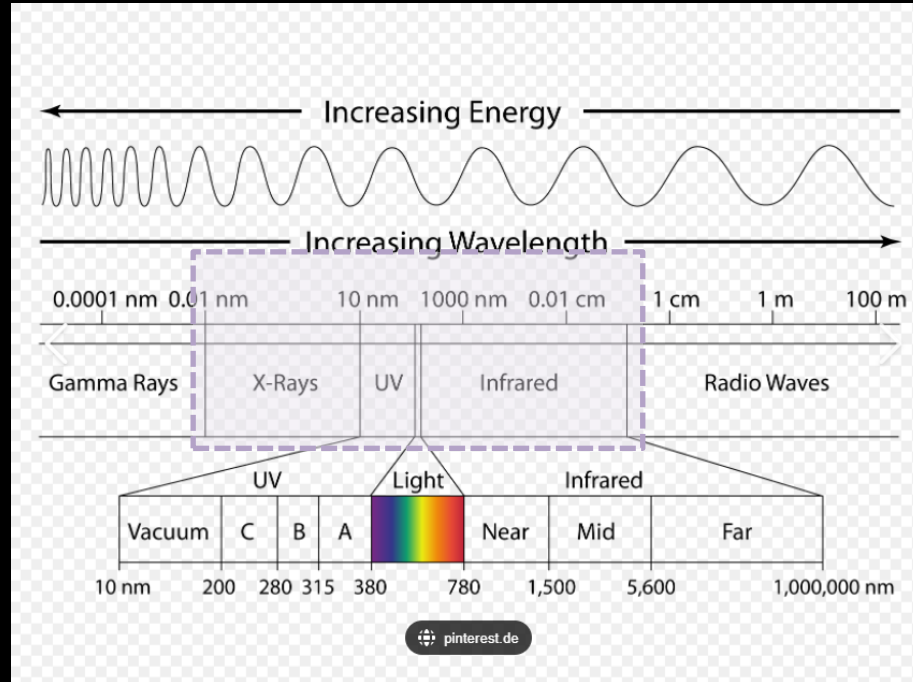

[electromagnetic spectrum - Bing images](#)

Spectral sensitivity of GSENSE400BSI-TVISB (not PulSAR)

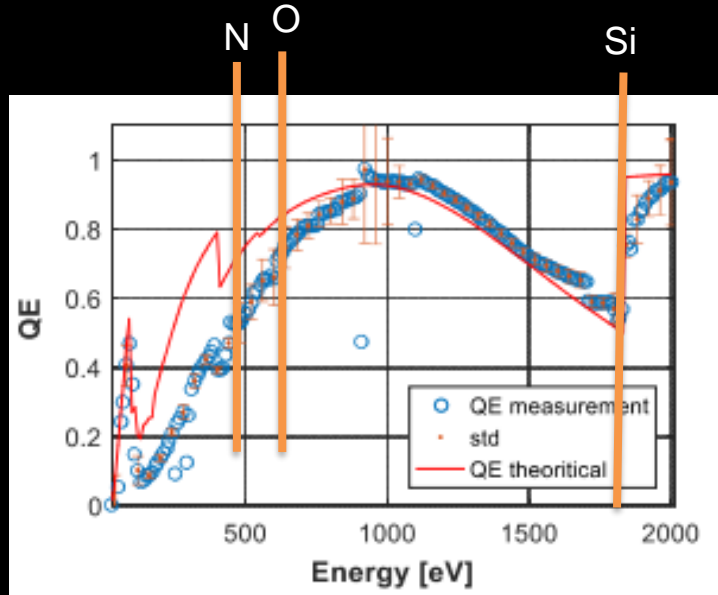
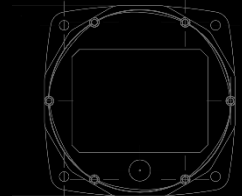

FIGURE 3. DhyanaX Quantum Efficiency measurement compared to the simple theoretical model given by coating and Si-Epi absorption (SiO 7.5 nm, SiN 63 nm and Si-Epi of 10 μm)

- Absorbance bands from Silicon, nitrogen and oxygen (vertical, orange lines)
- Passivation and anti-reflection layer (SiO 7.5 nm, SiN 63 nm) show transmission-profile for x-rays, which are finally absorbed in Si-Epi layer (thickness 10 μm) determining the QE-profile
- For >90eV x-ray transmission through SiO and SiN coating layer
- Measurements performed at SEXTANT beamline and SOLEIL synchrotron



Gpixel announce new PulSar technology

Expanding the spectral sensitivity: Removing AR-coating (GSENSE400SBSI)

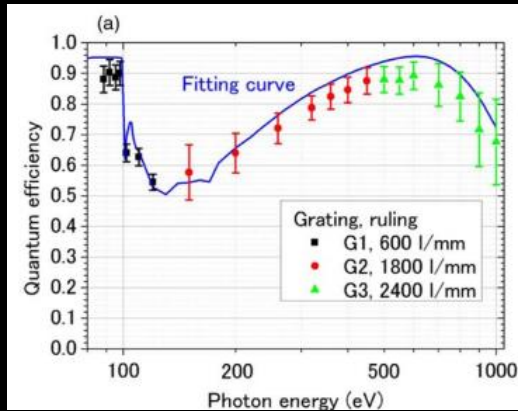

- The backside (incidence side) process is changed to increase soft X-ray and EUV sensitivity, and to reduce radiation damage
- After CMOS wafer processing, the sensor wafer is bonded onto a support wafer, and thinned down to a thickness of 3.5 μm
- To reduce dark current from the backside, boron is implanted with low energy and annealed on the backside
- wire bonding pads are formed
- \rightarrow The significant feature of this process is that there are no dielectric films for antireflection and protection on the backside to avoid soft X-ray and EUV attenuation, and to escape the chargeup of dielectric films by radiation

Fig. 2. (Color online) (a) Evaluation result of QE in 80–1,000 eV region. (b) Histogram of single event frequency with 300–1,000 eV photons. Horizontal axis shows digital number (DN) of the single event detection.

- Simplest dead layer (non-sensitive silicon layer on the sensor surface) matches the observed QE results
- A part of the generated electrons in cloud were recombined in the dead layer and were not accumulated at the photodiode as signal)
- Consequently, the detected electron number became smaller than the generated electron number
- \rightarrow **thinner dead layer together with a low reading noise and smaller sharing is crucial**

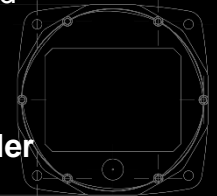

Gpixel announce new PulSar technology

Expanding the spectral sensitivity: Reduction of dead layer (GSENSE400BSI-PS)

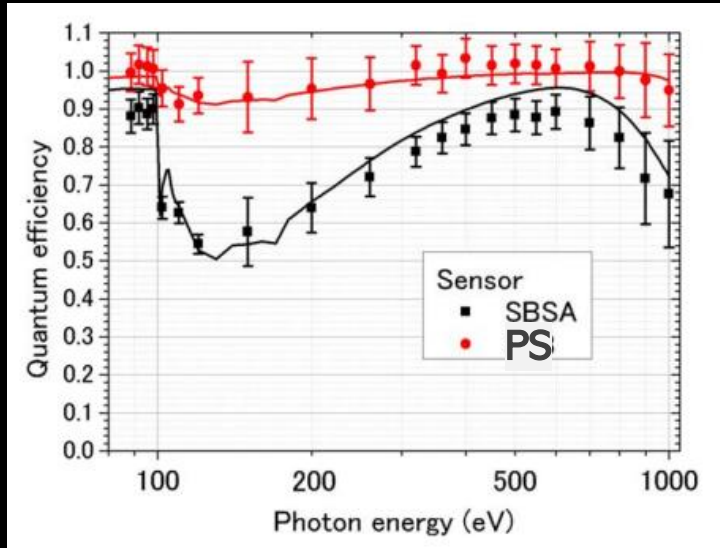
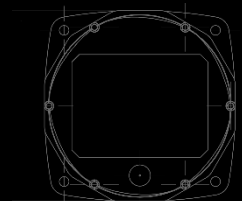

Fig. 1. (Color online) Evaluation of quantum efficiency (QE) of SBSA and SP3 sensors in 80–1000 eV energy range. The solid lines indicate the fitting result.

- further improvements to the backside process to afford a thicker Si layer of 9.5 μm
- based on the Gpixel BSI CMOS image sensor, GSENSE400SQBSI, which incorporates minor revisions in the peripheral circuits relative to the previous sensor, the GSENSE400BSI
- two changes to the backside fabrication process for the SP3 relative to the SBSA: the silicon thickness was changed from 3.5 to 9.5 μm to suppress radiation damage, and that the implantation energy was decreased by one digit to reduce the non-sensitive-layer thickness
- sCMOS sensor adopts a rolling shutter
- Sensor characterized at BL-10 beamline NEWSUBUARU synchrotron (Univ. Hyogo)
- Sensor temperature 42 grad Celsius



Gpixel announce new PulSar technology

Expanding the spectral sensitivity: Reduction of dead layer (GSENSE400BSI-PS)

- 80-1000eV range QE >90%
- We note that below 450 eV, the SBSA-sensor energy distribution exhibits a large low-energy tail. In contrast, that of SP3 exhibits no low-energy tail at 200 eV because the dead-layer thickness is reduced from 27 to 5 nm
- Thus, the SP3 sensor is able to resolve low-energy fluorescence corresponding to carbon (284 eV) and boron (188 eV). Here, we note that EUV photons (92 eV) are also resolved by the sensor
- The dark-current increase was measured as a function of the dosage
- Here, we note that silicon dioxide and silicon nitride insulator/dielectric layers can undergo charge-up, trapping photogenerated holes
- These deplete the Si-SiO₂ layer interface and activate its generation-recombination centers
- Subsequently, the dark-current increases along with the dark-current shot noise. This phenomenon can occur at both the Si rear and front sides

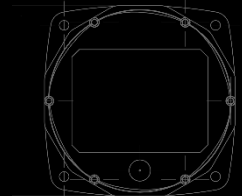

Gpixel announce new PulSar technology

Expanding the spectral sensitivity: Reduction of dead layer (GSENSE400BSI-PS)

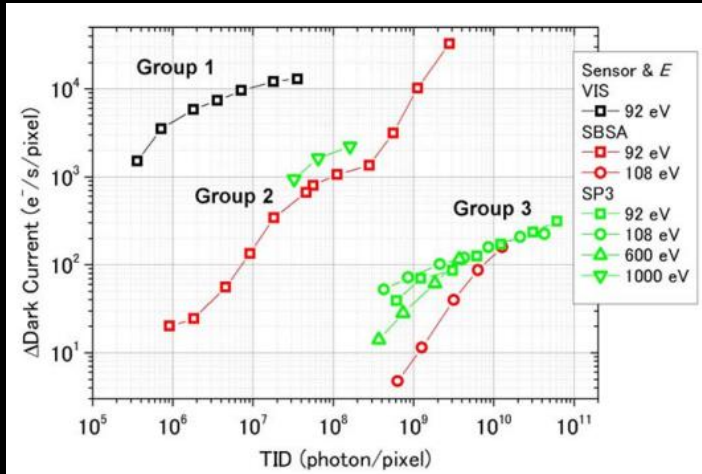

- In these devices, charge-up occurs in three regions: illuminated-surface layer, MOS-transistor gate insulator, and oxide layer on the photodiode's front side
- 1st group: suffer from a severe dark-current increase due to charge-up of the AR dielectric layers
- 2nd group: show a non-negligible dark current increase because the front-surface oxide of the photodiode is charged up by penetrative X-ray photons.
- 3rd group: exhibit a slight dark-current increase due to native oxide-layer charge-up

- The dark-current increase was measured as a function of the dosage
- Here, we note that silicon dioxide and silicon nitride insulator/dielectric layers can undergo charge-up, trapping photogenerated holes
- These deplete the Si-SiO₂ layer interface and activate its generation-recombination centers
- Subsequently, the dark-current increases along with the dark-current shot noise. This phenomenon can occur at both the Si rear and front sides



Gpixel announce new PulSar technology

Expanding the spectral sensitivity: Reduction of dead layer (GSENSE400BSI-PS)

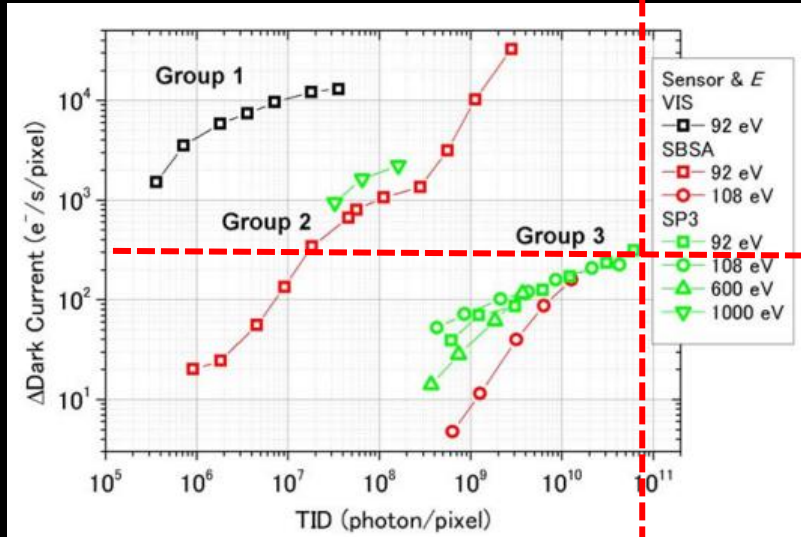

- Dark current enters acceptable regime for EUV ptychography (6×10^{10} photons/pixel)
- dark-current decreased by half for every temperature reduction of 5.7°C . Thus, the dark-current increase at -10°C was

EUV appli. limit

- The device dead layer thickness is only 5 nm, and its energy-resolving performance indicates that oxygen, nitrogen, carbon, and boron fluorescence can be identified. EUV photons can also be resolved. The device tolerance to soft-X-ray photons is also improved due to the thick Si layer of $9.5\ \mu\text{m}$.

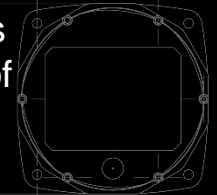

Gpixel announces new PulSar technology

Compare device specification

GSENSE400BSI → GSENSE400SBSI
(AR coating removed) (Dead layer thickness reduced)

→ GSENSE400BSI-PS
(Silicon thickness increased)

	Frame rate	Resolution	Dark current e-/s/pixel	Silicon thickness	Dead layer thickness	AR-coating/ μm	Low readout noise
PS	48 Fps (24HDR)	2048x2048	3.7 (@-7C)	9.5 μm	5 μm	x	2.5 e- rms
SB SI	48 Fps (24HDR)	2048x2048	300 (@31C)	3.5 μm	27 μm	x	2.6 e- rms
BSI	24 Fps (full frame)	2048x2048	1.5 (@-20C)	10 μm	???	SiO 7.5nm/ SiN 63nm	

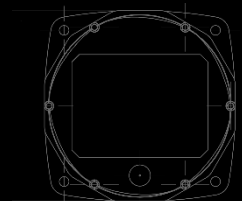

Gpixel announce new PulSar technology

Expanding the spectral sensitivity:

- Accessing VUV/EUV, soft X-ray and direct electron detection [vacuum ultra violet (VUV), extreme ultra violet (EUV)]
- Quantum efficiency approaching 100%
- Excellent resistance to radiation damage in soft x-ray detection appl.
- PulSar technology based on backside illuminated (BSI) scientific CMOS image sensor, GSENSE2020BSI
- GSENSE2020BSI already shows high sensitivity in far UV (122-200nm) and low energy electron detection (1keV-10keV)
- GSENSE2020BSI-PS: Removing of passivation layer on sensor surface (Anti-reflection coating) leads:
 - Higher sensitivity for shorter wavelength (accessing VUV/EUV and soft x-ray light)
 - Reduction degradation over time
 - Incorporation a new passivation technique:
 - Reduction of thickness of non-sensitive layer
 - Reduction of dark counts
 - Boosting the resistance to radiation damage

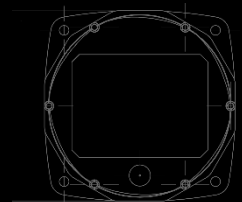

Gpixel announce new PulSar technology

Appendix I: PulSar intergration in MJ042-2MR-GP-P11-BSI

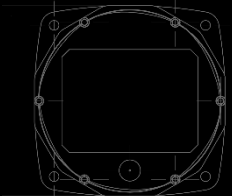
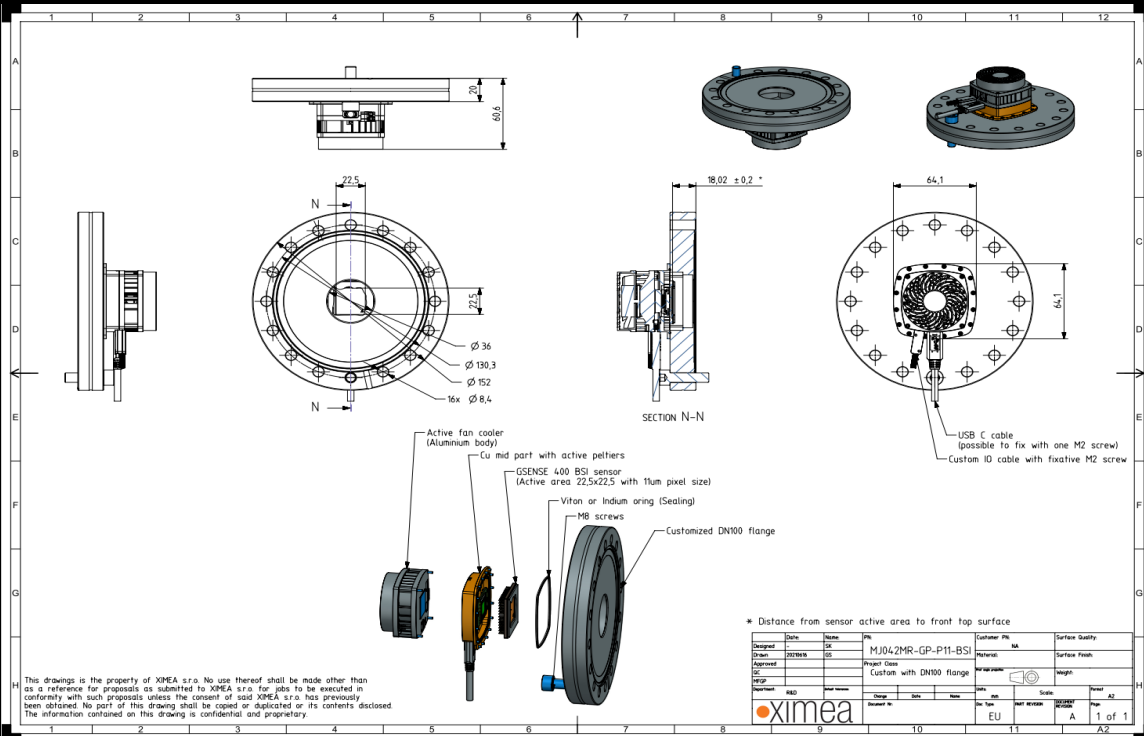

Gpixel announce new PulSar technology

Appendix II: Spectra collection

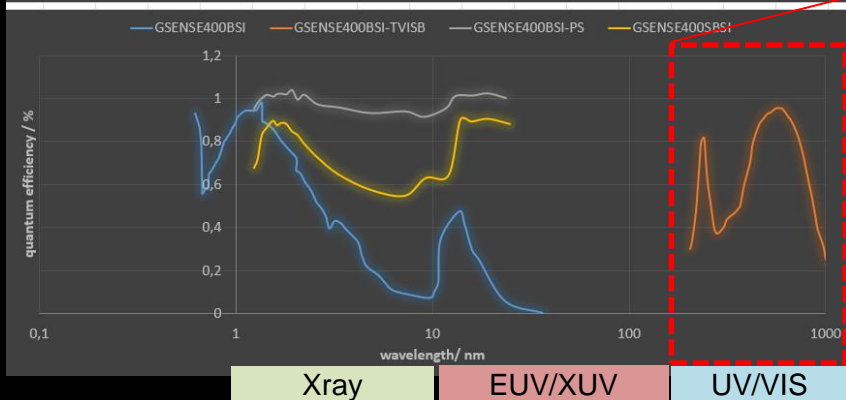
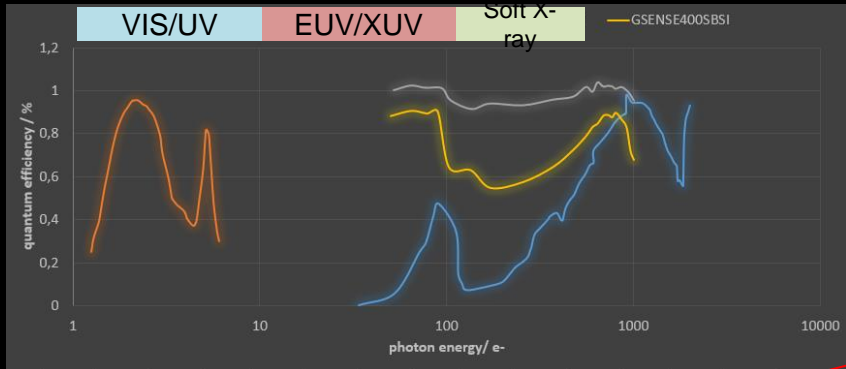

VIS spectral response slightly differ (GSENSE2020BSI-PS):

- PulSar footprint in VIS less sensitive
- PulSar optimized for EUV and Xray -regime

