

1 2 3 4 5 6 7 8

A

B

C

D

E

F

A

B

C

D

E

F

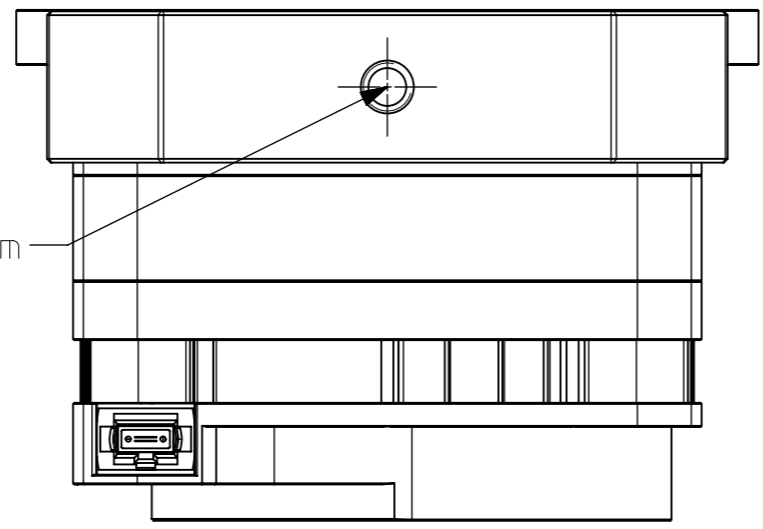

1/4-20 UNC ∇ max 7mm

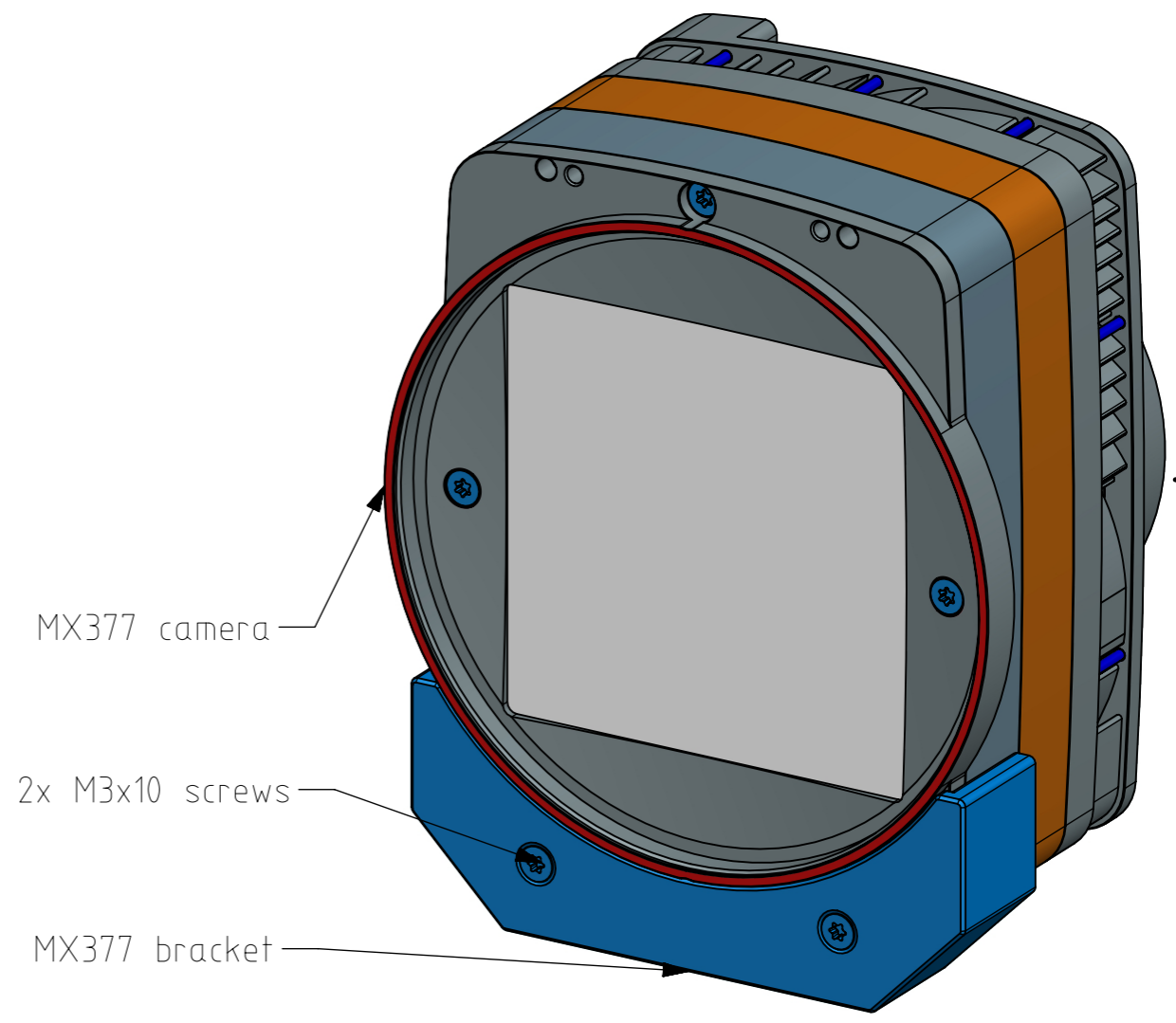
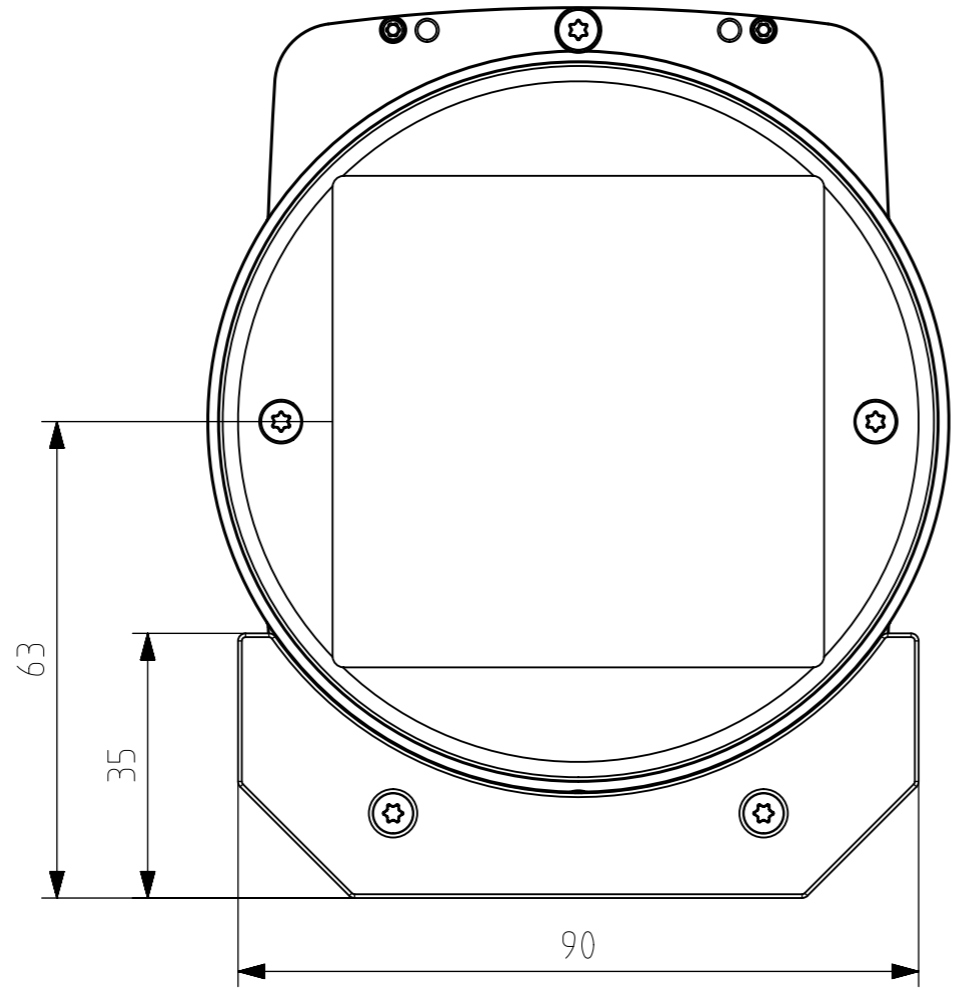
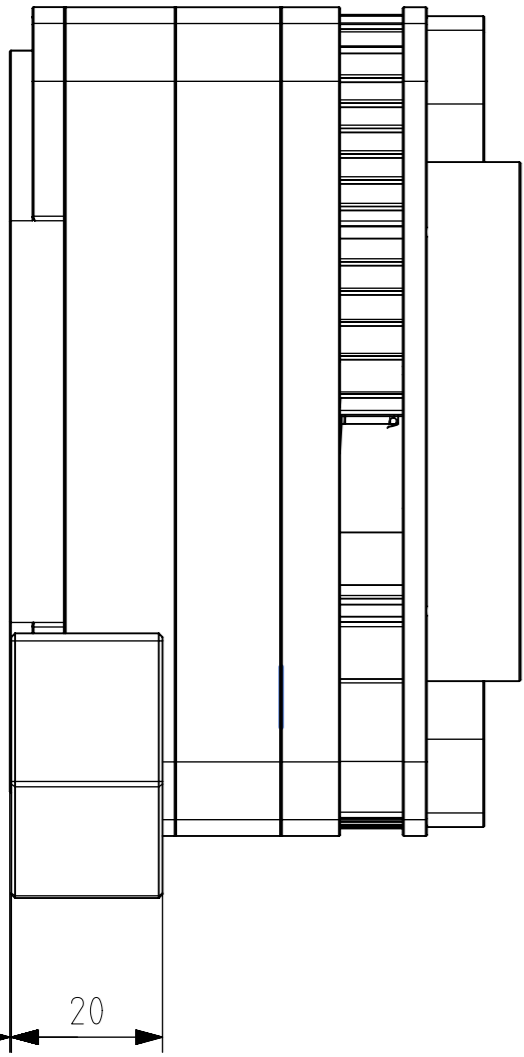

Date:	Name:	PN:	Customer PN:	Surface Quality:
Designed -	SK	MX377xG-GP	NA	Ra
Drawn 20210824	GS		Material:	Surface Finish:
Approved		with bracket kit	First angle projection	Weight:
QC			Units: mm	Scale: 1:1
MFGP		Change	Date	Name
Department: R&D	Default tolerances:	Document Nr:		Doc Type: EU
			PART REVISION	DOCUMENT REVISION
			A	1 of 1

This drawings is the property of XIMEA s.r.o. No use thereof shall be made other than as a reference for proposals as submitted to XIMEA s.r.o. for jobs to be executed in conformity with such proposals unless the consent of said XIMEA s.r.o. has previously been obtained. No part of this drawing shall be copied or duplicated or its contents disclosed. The information contained on this drawing is confidential and proprietary.

1 2 3 4 5 6 7 8 A3